

# Champ VMVL LED light fixtures for hazardous areas

Safe. Reliable. Efficient.  
3,000 to 7,000 lumens



Powering Business Worldwide

Eaton's Crouse-Hinds series Authorized distributor - Kunshan beiyuan electric co.,ltd./ csr@ksbyel.com

The Champ VMVL light fixture is a field-proven design that helps ensure safety, reliability and performance in harsh and hazardous areas. The optional M3 configuration adds intelligent control and insight capabilities to deliver more operational value and better total cost of ownership.

## Design features - All Champ VMVL LED models

### LONG-LIFE RELIABILITY

#### A Serviceable drivers

- Fully serviceable drivers are isolated from the primary heat source (LED engine) to maximize economic life

#### B Thermal management

- Heat fins help ensure proper air flow and facilitate dust-shedding for effective heat dissipation and thermal management of LED engine

#### C Performance in extreme environments

- Up to 60,000 hours lifetime at +65 °C
- Operating ambient -40 °C to +65 °C
- Type 4X, IP66
- Corrosion-resistant aluminum housing with Corro-free™ epoxy power coating
- Vibration tested in accordance with Section 33 of UL 844
- Impact tested in accordance with Section 68 of UL 844
- 6 kV surge protection

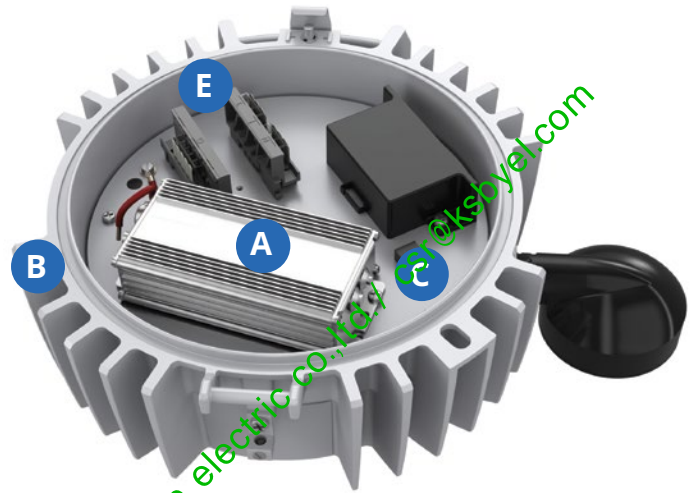

### INSTALLATION EASE

#### D Retrofit-friendly universal top hats

- 7 mounting module styles help ensure that the fixtures are installed in the correct location to properly light your facility.
- Crouse-Hinds series Champ LED luminaires utilize the same mounting modules as our legacy products, simplifying installation and significantly reducing costs in retrofit projects
- We also offer mounting adapters and kits for quick connection to other manufacturers' modules (Appleton, Thomas and Betts, GE)

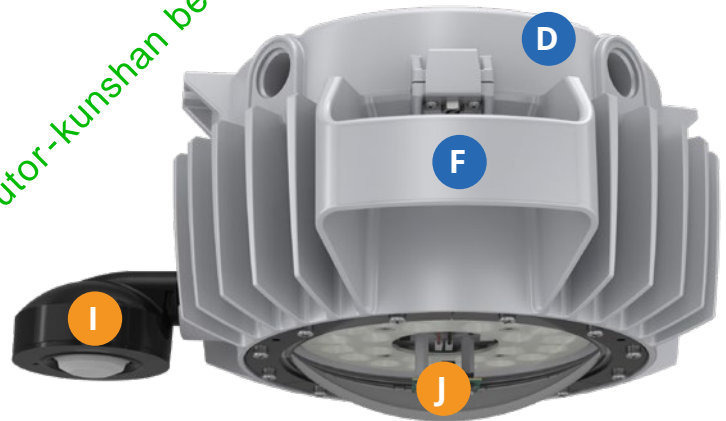

#### E Lever lock connectors and terminal blocks

- Plug and play wiring simplifies and speeds installations
- Accepts 10–20 AWG wire

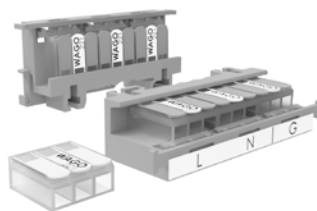

Image is representative only.

#### F Carry handle

- Integral carrying handle simplifies transportation and installation at the job site



# LIGHT PERFORMANCE AND QUALITY

## G Custom optics and colors

- Directs light where you need it, helping eliminate gaps and dark spots
- Can potentially reduce the number of light fixtures required in your application
- Green and amber LEDs available for wildlife conservation applications



### TYPE I

Long and rectangular for hallways, walkways, loading docks, catwalks



### TYPE III

Stanchion and wall-mount light distribution, minimizing spillover on the wall



### TYPE V

Regular circular distribution pattern for high/low bay indoor and outdoor ceiling or pendant mount lighting

## H Glass or polycarbonate lens with clear or diffused finish

- A variety of lens materials and finishes available to meet customer requirements or preference

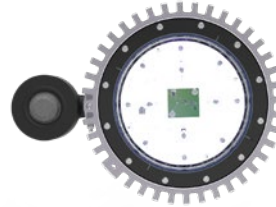

### 5000 K – COOL

Crisp, bright white with a blue hue

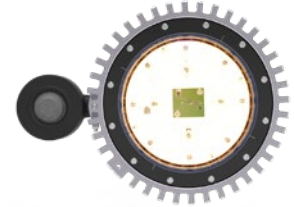

### 3000 K – WARM

Warm white with a yellow hue

**Note:** Also available in 2200 K and 4000 K upon request

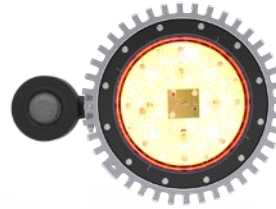

### TRUE AMBER

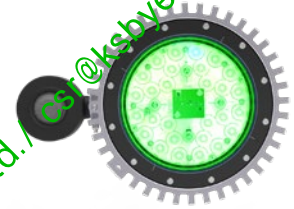

### TRUE GREEN

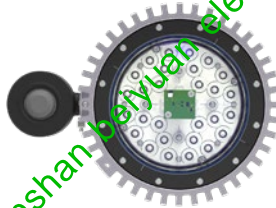

### CLEAR

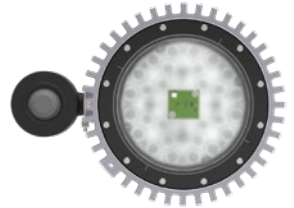

### DIFFUSED

# Additional Design features - VMVL M3 models with intelligent control and insight

## SENSING, CONTROLLING AND COMMUNICATING\*

### I Intelligent multi-sensor (optional accessory)

- Replaceable sensor can be factory installed at purchase, or field installed at a later date
- Sensor is integral to light fixture—no field wiring required
- PIR occupancy sensor with LED indicator
- Automatically illuminates the area once presence is detected
  - Light turns back off when presence is no longer sensed for a set period of time
- Photo sensor for daylight harvesting and lux reporting
  - Measures available daylight and adjusts light level of the luminaire to maintain desired light levels

### J Smart controller

- Controller manages dimming, scheduling and grouping functionality, as well as notifications and alarming
- 90-minute on-board back-up memory maintains system clock and control profiles in event of power disruption
- User-selected option for thermal-rollback enables driver and LED protection during extreme temperature events
- Every VMVL M3 intelligent light fixture features connectivity capability

### K Integrated antenna

- Attached to the optics board inside the lens, maintaining the fixture's hazardous ratings
- Connects easily to Eaton's Brightlayer Lighting control interface. No complex hardware required to commission and control the lights
- Bluetooth Low Energy (BLE) protocol enables decentralized control of the system without complex and expensive IT network gear
- Up to 30 foot range fixture-to-fixture
- Backed by Eaton's Cybersecurity Center of Excellence, which enforces security through training, technology, best practices and industry standards

\* These design features are only available on Champ VMVL M3 Intelligent light fixtures and require an active Brightlayer Lighting software subscription to enable. A Brightlayer Lighting plan can be activated at any time.

For more information on Champ VMVL M3 Intelligent fixtures and Brightlayer Lighting software, please refer to pages 7-9.

# Champ VMVL LED product specifications

## Certifications and compliances

### NEC®, CEC and IEC<sup>A</sup>

- Class I, Division 2, Groups A, B, C, D
- Class II, Division 1, Groups E, F, G
- Class III
- Class I, Zn.2 AEx ec IIC, ZN.21 AEx tb IIIC
- Class I, Zn.2 Ex ec IIC, ZN.21 Ex tb IIIC
  - Ex ec IIC T\* Gc
  - Ex tb IIIC T\*° C Db
  - II 3 G Ex ec IIC T\* Gc
  - II 2 D Ex tb IIIC T\*°C Db
- Simultaneous presence
- Marine and Wet locations, Type 4X, IP66

### UL® standards

- UL 844; UL913<sup>A</sup>; UL 1598; UL 1598A; UL 8750; UL 50E
- UL 60079-0; UL 60079-7; UL 60079-11<sup>A</sup>; UL 60079-31

### CSA® standards

- CSA C22.2 No. 137; CSA C22.2 No. 94.2; CSA C22.2 No. 250.0, CSA C22.2 No. 250.13
- CSA C22.2 No. 60079-0; CSA C22.2 No. 60079-7; CSA 22.2 No. 60079-11<sup>A</sup>; CSA C22.2 No. 60079-31

### IEC and EN standards

- IEC/EN 60079-0; IEC/EN 60079-7; IEC/EN 60079-11<sup>A</sup>; IEC/EN 60079-31

### Luminaire markings

- IECEx UL 19.0039X
- DEMKO 19 ATEX 2118X
- DEMKO 19 ATEX 2119X

### Standard materials

- **Lamp housing and adapter:** die cast aluminum with Corro-free epoxy powder coat
- **Lens:** heat- and impact-resistant glass (clear or diffused) or polycarbonate
- **Gaskets:** silicone
- **External hardware:** stainless steel
- **Factory sealed:** no external seal required
- **Contains no mercury** or other hazardous substances

## Electrical ratings and weights

Catalog number	Weight (kg) (lb)	Nominal lumens (lm) <sup>B</sup>	Efficacy (lm/W)	Nominal Wattage (W)	Max. <sup>E</sup> Wattage (W)	Voltage	Nominal Amperes (A)	Max. <sup>E</sup> Amperes (A)	Power factor	THD (%)	Surge protection (kV)
VMVL-3-UNV1	5.45 (12)	3225	153	21	23	100–277 VAC, 50/60 Hz; 127–250 VDC	0.22–0.08	0.26	> 0.90 <sup>D</sup>	<15	6
VMVL-5-UNV1	5.45 (12)	5456	155	35	39	100–277 VAC, 50/60 Hz; 127–250 VDC	0.36–0.13	0.45	> 0.90	<15	6
VMVL-7-UNV1	5.45 (12)	7607	152	50	54	100–277 VAC, 50/60 Hz; 127–250 VDC	0.5–0.19	0.60	> 0.90	<15	6
VMVL-AT-UNV1	5.45 (12)	2030	75	27	33	100–277 VAC, 50/60 Hz; 127–250 VDC	0.27–0.10	0.37	> 0.90	<15	6
VMVL-GT-UNV1	5.45 (12)	2900	145	20	23	100–277 VAC, 50/60 Hz; 127–250 VDC	0.2–0.07	0.27	> 0.90 <sup>D</sup>	<15	6

<sup>A</sup> The "Ex ia" protection technique and the associated UL 913, UL 60079-11, CSA 60079-11 and IEC/EN 60079-11 standards are applicable only to VMVL M3 models with intelligent control and insight.

<sup>B</sup> Nominal lumens are based on Type V optics, 5000 K CCT with a clear glass lens. The nominal wattage is measured at 120VAC.

<sup>C</sup> Custom optics not available with colored LEDs.

<sup>D</sup> For VMVL-3-UNV1 & VMVL-GT-UNV1: PF>0.9 from 100-255 VAC.

<sup>E</sup> In the event of an abnormal condition (single-string functioning), the maximum wattage and current will be reached.

<sup>F</sup> Refer to the authorized distributor price book for Crouse-Hinds standard Terms and Conditions. Standard 7-year warranty extends to 10-year warranty from date of installation with active subscription to Brightlayer Lighting software plan

## Fixture Warranty

- 7-year fixture warranty<sup>F</sup>

## LED system

- **Energy-efficient technology:** up to 77% energy savings over HID fixtures
- **High-intensity** discrete power emitters
- **Standard:** cool white (5000 K, 70 CRI); **optional:** warm white, (3000 K, 80 CRI), neutral white (4000 K, 70 CRI), **deep warm** (2200 K, 70 CRI, DarkSky ready)
- **Custom Type I, III and V optics available**<sup>C</sup>

## Colored LED options

- **Available in true green and true amber** for wildlife friendly applications<sup>C</sup>
- **Reduction in light pollution** for night space observation and sky glow due to isolating blue wavelength in red and amber colors
- **Improves visibility for telescopes** in observatories during night sky space exploration

## Temperature codes, UNV1 driver

UNV1: VMVL-3 to VMVL-7	40 °C		55 °C		65 °C	
	M3	M2	M3	M2	M3	M2
Class I, Division 2	T5	T5	T5	T5	T5	T5
Class II, Division 1	T4	T6	T4	T6	T4	T6
Simultaneous presence Class I, Division 2 Class II, Division 1	T3B	T3B	T3B	T3B	T3B	T3B
Zone 2, AEx ec ia IIC Zone 2, Ex ec ia IIC	T4	T4	T4	T4	T4	T4
Zone 21, AEx ia tb IIIC Zone 21, Ex ia tb IIIC	T135	T65	T135	T85	T135	T85

## Photometrics

For IES photometric files, please refer to the resource tab of the [VMVL LED product page](#) on Eaton.com.

# Ordering information

## Part number example: VMVL-3-N-A2-R1-G-UNV1-SS12-M3

Champ VMVL LED, 3000 lumens, 4000 K neutral white, ¾-inch pendant mount, Type I optics, clear glass lens, wire guard, 100–277 Vac driver, integrated sensor, intelligent light fixture.

# VMVL - 3 - N - A2 - R1 - - G - UNV1 - SS12 - M3

### Light source/intensity

<b>3</b>	3250 nominal lumens
<b>5</b>	5537 nominal lumens
<b>7</b>	7442 nominal lumens
<b>AT<sup>A</sup></b>	True Amber LEDs (dominant wavelength 585–595 nm)
<b>GT<sup>A</sup></b>	True Green LEDs (dominant wavelength 520–535 nm)

### Color temperature

<b>BLANK</b>	5000 K, 70 CRI (cool white)
<b>N<sup>A</sup></b>	4000 K, 70 CRI (neutral white)
<b>W</b>	3000 K, 80 CRI (warm white)
<b>D<sup>A</sup></b>	2200 K CCT, 70 CRI (deep warm white)

### Mount

<b>BLANK</b>	No mounting module
<b>J5</b>	1-½-inch stanchion, 25° angled
<b>P5</b>	1-½-inch stanchion, straight
<b>A2</b>	¾-inch pendant
<b>A3</b>	1-inch pendant
<b>H2</b>	¾-inch offset pendant
<b>T2</b>	¾-inch wall
<b>T3</b>	1-inch wall
<b>C2</b>	¾-inch ceiling
<b>C3</b>	1-inch ceiling
<b>B2</b>	¾-inch dust shedding
<b>B3</b>	1-inch dust shedding
<b>A20</b>	20 mm pendant
<b>A25</b>	25 mm pendant
<b>C20</b>	20 mm ceiling
<b>C25</b>	25 mm ceiling
<b>T20</b>	20 mm wall
<b>T25</b>	25 mm wall

### Lens guard

<b>BLANK</b>	No guard
<b>G</b>	Wire guard

### Lens material

<b>BLANK</b>	Clear glass
<b>DG</b>	Diffused glass <sup>CDE</sup>
<b>PC</b>	Polycarbonate <sup>C</sup>
<b>UP</b>	Uplight glass globe refractor <sup>CE</sup>

### Connectivity

<b>M2</b>	Standard fixture
<b>M3</b>	Intelligent fixture

### Accessories and options

<b>BLANK</b>	No external sensor included
<b>SS12<sup>G</sup></b>	Sensor with barrier board (12–30 ft mounting height)
<b>SC</b>	Safety cable
<b>TB6</b>	6-pole terminal block
<b>TM<sup>F</sup></b>	Trunnion mount kit with pin

### Optics

<b>BLANK</b>	Type V optic standard
<b>R1<sup>B</sup></b>	Type I optic (all mounts minus ceiling)
<b>R3<sup>B</sup></b>	Type III optic (all mounts minus ceiling)
<b>R1A<sup>B</sup></b>	Type I optic (ceiling with conduit 45° counterclockwise from top hat hinge)
<b>R3A1<sup>B</sup></b>	Type III optic (ceiling with conduit 45° counterclockwise from top hat hinge)

### Voltage

<b>UNV1</b>	100–277 Vac, 50/60 Hz; 127–250 Vdc
-------------	------------------------------------

### Subscription Add-Ons

#### Brightlayer service plan

<b>BLI-CH-DL-ADV<sup>G</sup></b>	1 year Brightlayer Lighting plan (1 device)
----------------------------------	---

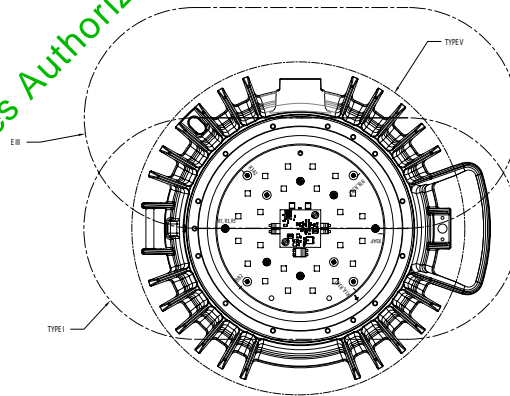

Type R1 and R3 optic

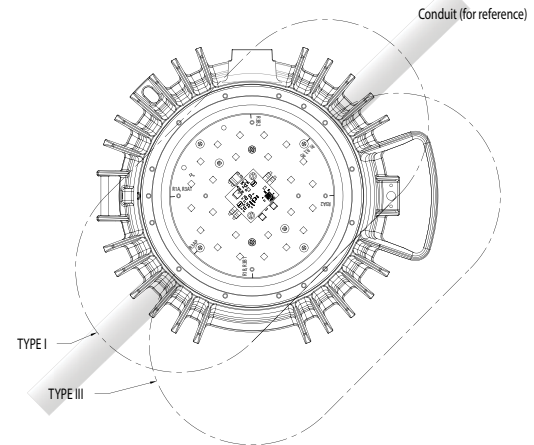

Type R1A and R3A1 optic

<sup>A</sup> Consult customer service for lead time.

<sup>B</sup> Additional clocked optics available upon request. Please contact customer service.

<sup>C</sup> Only one lens option may be selected.

<sup>D</sup> UL/cUL only, not available for IECEx/ATEX.

<sup>E</sup> Available with Type V optic only.

<sup>F</sup> Must be used with ceiling mounting modules. For suffix TM, the luminaire is restricted to Class I, Division 2 applications only when it is used for pole mounting.

<sup>G</sup> Only available on Champ M3 model. An active Brightlayer Lighting subscription is required to enable sensor function and intelligent controls.

# Accessories

## Mounting modules



Stanchion—straight



Stanchion—25° angled



Wall



Ceiling



Cone pendant



Pendant

Hub size	Stanchion—straight	Stanchion—angled	Pendant	Offset pendant	Wall	Ceiling	Cone pendant
3/4 inches	—	—	APM2	HPM2	TWM2	CM2	BPM2
1 inch	—	—	APM3	—	TWM3	CM3	BPM3
1-1/2 inches	PM5	JM5	—	—	—	—	—
20 mm	—	—	APM20	—	—	—	—
25 mm	—	—	APM25	—	TWM25	—	—

Mounting module	lb	kg
Pendant	1.25	0.57
Cone pendant	4.00	1.81
Flexible pendant	1.50	0.68
Ceiling	2.75	1.25
Wall	4.50	2.04
Angled stanchion	3.50	1.59
Straight stanchion	4.50	2.04

## Mounting adapters

CHMM1	Mounting adapter for Appleton MercMaster III mounts
CHMM2	Mounting adapter for Appleton MercMaster II mounts
CHMM3	Mounting adapter for Thomas and Betts HazLux mounts
CHMM4	Mounting adapter for GE H2 Filtr-Gard mounts

## Replacement driver kits

VMVL-3-UNV1-M3-DRIVER KIT	UNV1 replacement driver kit for VMVL-3 fixtures
VMVL-5-UNV1-M3-DRIVER KIT	UNV1 replacement driver kit for VMVL-5 fixtures
VMVL-7-UNV1-M3-DRIVER KIT	UNV1 replacement driver kit for VMVL-7 fixtures
VMVL-AT-UNV1-M3-DRIVER KIT	UNV1 replacement driver kit for VMVL True Amber
VMVL-GT-UNV1-M3-DRIVER KIT	UNV1 replacement driver kit for VMVL True Green

## Mounting kits and hardware

VMVL S812 K1	Trunnion mount kit with pin <sup>ABC</sup>
VMVL S812 K1 DBR	PVC-coated trunnion mount kit with pin <sup>ABC</sup>
VMVL S831 K1	Safety cable
VMVL S890 K1	Quick clip

A Available with ceiling mounted modules only.

B Luminaire is restricted to Class I, Division 2 applications only when it is used for pole mounting.

C Can be mounted in 90°, 113° and 135° with fixed locking positions.

## Intelligent lighting and control components

NHZS-SS12 KIT	Sensor and barrier assembly kit <sup>D</sup>
---------------	--

<sup>D</sup> Available on Champ M3. An active Brightlayer Lighting plan is required for sensor function and intelligent controls.

## Lens guard

PA3001	Wire guard
PU3003	Uplight wire guard



CHMM1



CHMM2



CHMM3



CHMM4



VMVL S812 K1



PA3001



NHZS-SS12 KIT



PU3003

# The benefits of Champ M3 Intelligent lighting

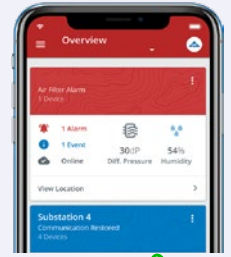
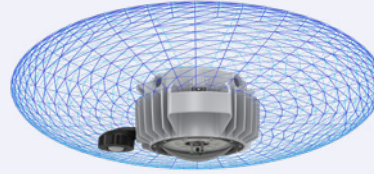

**Maintain up-time and minimize maintenance** costs by operating your lighting WHEN and WHERE you need it

**Maximize energy savings** and help achieve sustainability targets by reducing unnecessary light use.

**Improve safety and alarming** with real-time monitoring that helps minimize personnel time in hazardous areas

**Easily configure and manage your lights** with intuitive commissioning and control through the Brightlayer app

Champ™ light fixtures, renowned for their reliability and safety in harsh and hazardous lighting applications, are now available with intelligent control and insight capabilities, delivering more operational value and **up to double the fixture lifetime** versus a non-controlled LED.

Combining our advanced LED lighting design with communications and sensing technology and the intuitive Brightlayer Lighting app, you now have full lighting control at your fingertips — **improving safety, maximizing energy savings and minimizing maintenance costs**. Users can set customized fixture behavior and optimize light levels by site—helping minimize energy and maintenance costs.

The system requires **no additional wiring, hardware, IT infrastructure, or “always on” cloud connection**. A built-in mesh network allows each fixture to communicate with up to 100 other fixtures in range, automatically syncing updates across the network. All communications are protected by **fully certified cybersecurity protocols**, helping ensure secure and reliable performance.



## Champ Intelligent is Brightlayer Ready

Champ Intelligent light fixtures utilize **Brightlayer™ Lighting**, part of Eaton's portfolio of power and energy software and services that enhance assets with control, monitoring and insights to reduce risk and improve safety, efficiency, resiliency and sustainability.

Through Brightlayer Lighting, we combine deep electrical expertise with connected hardware, intelligent software, and expert services — delivering integrated solutions that help businesses better manage power to drive real operational value.

See page 8 for an overview of the lighting control functionality available with a Brightlayer Lighting subscription plan.



Learn more about Brightlayer Lighting  
Scan QR code or go to:

[Eaton.com/BrightlayerLighting](https://Eaton.com/BrightlayerLighting)

# Champ M3 Intelligent lighting control functionality



## Live fixture ID

Our intuitive app-based dashboard enables quick and easy identification of individual lights installed in the field. Simply select "live id" for a specific fixture and it will cycle on and off three times.



## Device grouping <sup>A</sup>

An added benefit that maximizes control in a defined area. By grouping light fixtures, the same control settings can be applied to them all, increasing efficiency and response time.



## Wireless ON/OFF and dimming

Turn lights on and off directly from the app. Reduce energy consumption by setting dimming levels or high end trim. Used in conjunction with other control features, such as scheduling and occupancy sensing, to further improve energy savings.



## Intelligent scheduling <sup>A</sup>

Allows for improving energy efficiency during non-operational hours. Easy app-based configuration lets a user set up schedules for lights to be on and off at pre-defined times, removing the challenges of manual management.



## Occupancy sensing <sup>A</sup>

Ideal for areas that see infrequent traffic, such as storage areas of warehouses. Sensor controls can automatically illuminate the area once presence is sensed and turn lights back off when presence is no longer sensed.



## Daylight harvesting <sup>A</sup>

Allows for use of the daylight and adjusts the light level of the luminaire to maintain desired light levels. It is best suited for outdoor environments or indoor areas where daylight is present during operational hours of a facility.

Provide the **RIGHT** amount of light, **WHEN** and **WHERE** you need it

With Brighlayer Lighting's intuitive app-based interface, you can utilize combinations of the Champ Intelligent control functions across your facility to optimize light levels by site, while minimizing run time to lower your energy and maintenance costs.



### Site 1: Low traffic, remote or restricted areas

- Keep lights off or dimmed to a safe minimum
- Utilize occupancy sensing to immediately bring grouped lights to a working level when triggered by movement
- Return lights to OFF or dimmed setting after a set period of inactivity

### Site 2: High traffic area with heavy employee activity, typically during shifts

- Schedule lights to be OFF during non-operational hours and turn on when work starts
- Utilize daylight harvesting where applicable for system-driven changes of fixture light output to maintain consistent lumen levels throughout the day

# Champ standard and intelligent fixture options

## The Champ M2 offers a classic, reliable lighting solution for a variety of applications

The **hardware only plan** provides a standard fixture without controls or sensing capabilities. The Champ M2 cannot be upgraded to add sensing or intelligent lighting control features at a later date.

## The Champ M3 Intelligent offers advanced sensing and controls for improved convenience and savings—with the option to connect now or later

The **Brightlayer Lighting subscription plan** provides customized lighting control with a wide range of intelligent features. Create lighting groups and set light levels that can be managed by schedule, available daylight and occupancy. Additionally, you can easily see each fixture's estimated remaining usable life

**Control-ready** is the default for Champ M3 light fixtures if a Brightlayer Lighting plan is not purchased. Control-ready fixtures can be upgraded to add intelligent control at a later date by adding the subscription plan (and a sensor if one is not already installed).

	Champ M2	Champ M3	
	Hardware Only	Control Ready	Brightlayer Lighting

### SUPPORT

Pre-sale product training and lighting layout support	●	●	●
Post-sales technical support	●	●	●
Warranty	5 years	7 years	10 years

### LIGHTING CONTROL FUNCTIONALITY

Wireless on/off/dimming		○	●
Live fixture ID		○	●
Fixture grouping		○	●
Advanced scheduling		○	●
Occupancy sensing		○	●
Daylight harvesting		○	●

### LIVE INSIGHTS AND DATA

Remaining usable life		○	●
-----------------------	--	---	---

### OPERATION AND HARDWARE

iOS-based control and commissioning		○	●
Support for multiple fixtures, sites, groups and users		○	●

○ – Feature can be enabled in the future with the addition of sensor and Brightlayer Lighting subscription.  
 ● – Feature is available by default. Sensor required.

## Safety and support



Get peace of mind and maximize protection on your fixtures with **extended warranties up to 10 years** that don't start until the product is installed on your site.



In the unlikely event that connection is lost, fixtures will default to Always On mode to **help ensure a safe environment for personnel.**



Users can enable optional **overtemperature protection to help protect fixtures** if the environment exceeds the rated temperature.

# Dimensions

**Ceiling**

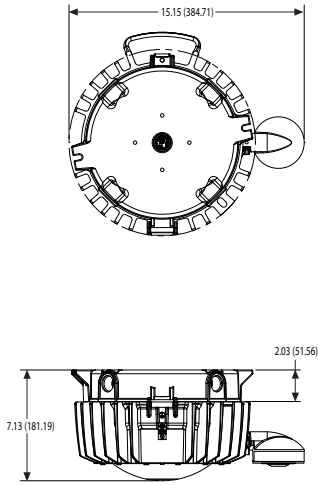

**Pendant**

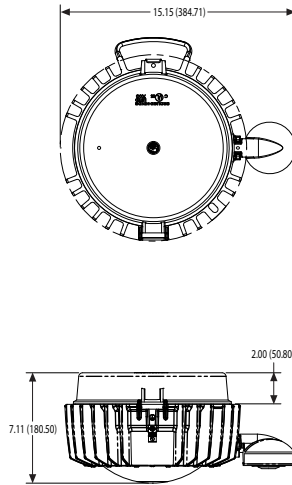

**Cone**

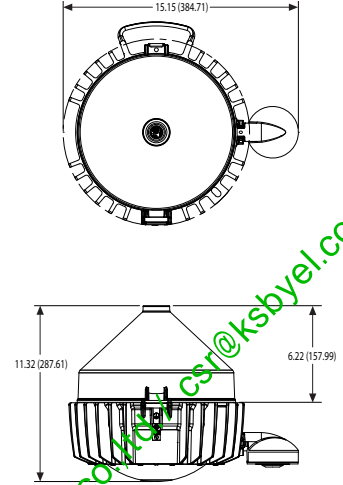

**Stanchion—straight**

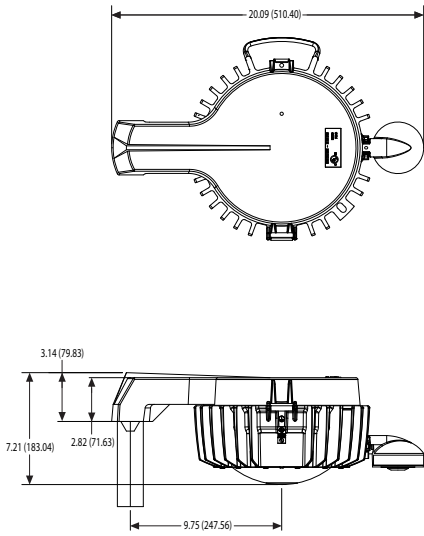

**Wall**

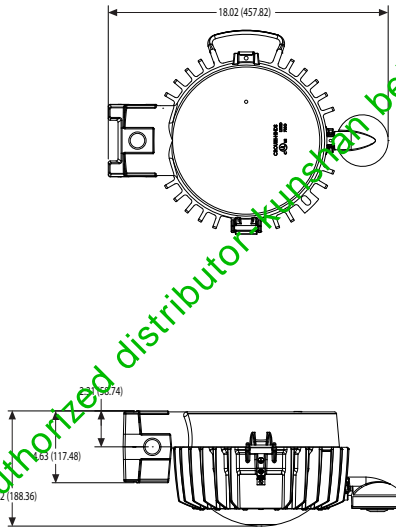

**Stanchion—25° angled**

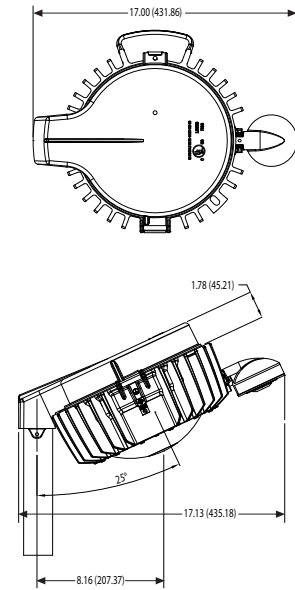

**Trunnion**

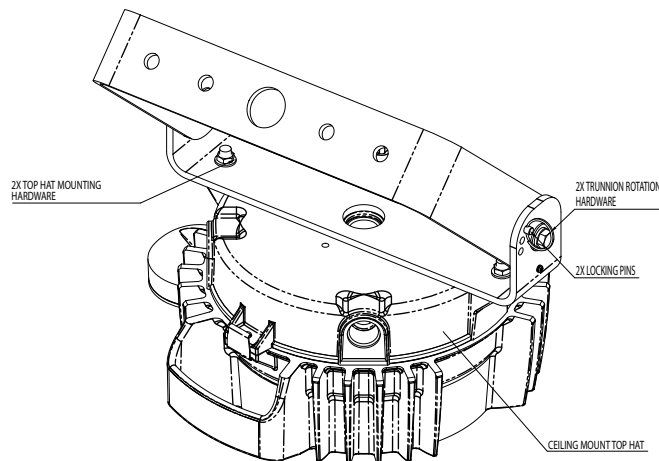

Eaton's Crouse-Hinds series Authorized distributor: Kunshan beiyuan electric control, csr@ksbyel.com

# Integral sensor coverage (M3 models)

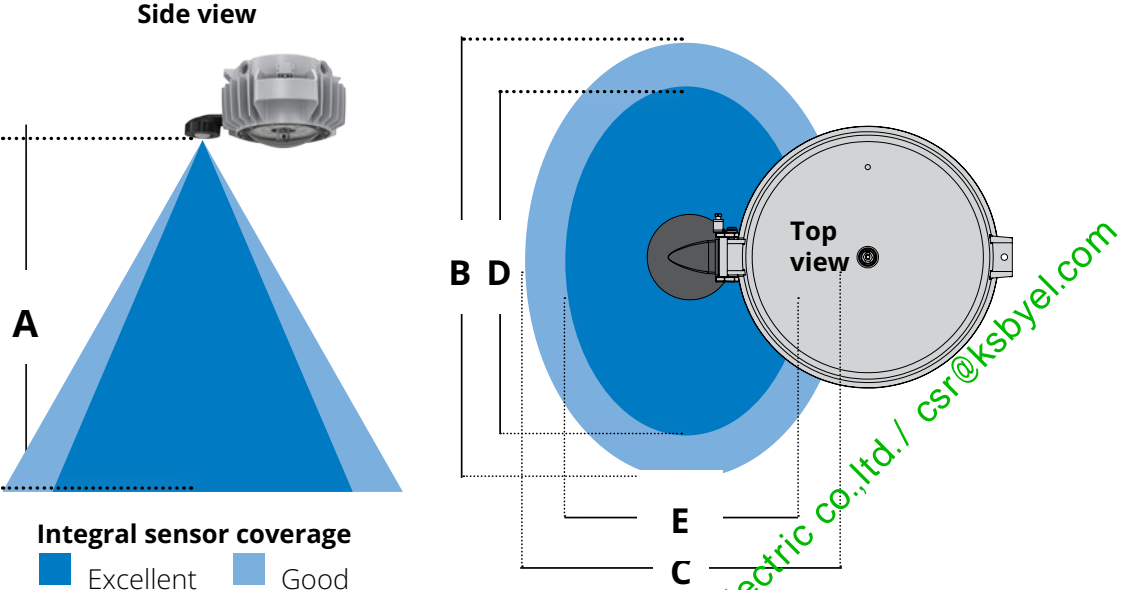

Mounting height of fixture <b>A</b>	Good coverage		Excellent coverage	
	<b>B</b>	<b>C</b>	<b>D</b>	<b>E</b>
12	15	12	12	9
30	40	30	36	30

Numbers above are listed in feet



# Lighting layout, analysis and design support for Crouse-Hinds series light fixtures

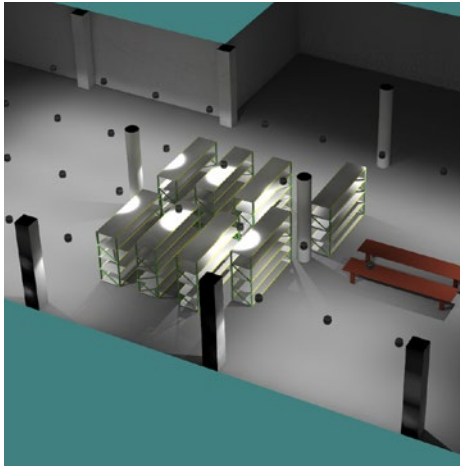

Eaton offers a complimentary solution for lighting designers and engineers looking for a state-of-the-art, effective and professional light planning software package.

From simple layouts to complex drawings, our industrial and hazardous area lighting design engineers will work with you to deliver precise, efficient, application and environment-appropriate lighting designs. Our experts can save you time and money by creating a virtual model of a proposed design, revealing luminaire characteristics and effects that would be hard to detect in anything short of the completed installation

*If ordering M3 or M3 with Brightlayer Lighting, a lighting and controls layout is required for correct sensor placement and lighting control.*

## We provide the following to you:

- 3D fixture placement with comparison of alternate fixtures and mounting heights
- Point-by-point footcandle diagram calculations
- AutoCAD drawings overlaying customer floorplans
- Complete bill of material

## Application benefits:

- Generates results showing expected light readings in either footcandles or LUX
- Provides professional quality summary reports
- Allows for energy evaluation reporting
- Planning for whole buildings, including outdoor spaces
- Document your results with photo-realistic visualizations
- Import AutoCAD drawings to use as a background guide with light fixture planning

## Two steps to get started:

1 [Click here](#)

To download the latest version of [DIALux](#). DIALux is free of charge and can be downloaded in many languages.

2 [Click here](#)

[Click here to download the Eaton's Crouse-Hinds series plugin.](#)

The DIALux software comes without any luminaire (photometric) data. This data (called a "plugin") must be installed separately. The Eaton's Crouse-Hinds series plugin includes the complete photometric database of Eaton's Crouse-Hinds series lighting products.

**Note:** Users who have already downloaded and installed any DIALux program only need to install the Eaton's Crouse-Hinds series plugin. Our plugin will work with either DIALux or DIALux EVO lighting software programs.



Take advantage of our lighting layout services today

Complete our lighting layout request form and send any supporting project information to [lightinglayouts@eaton.com](mailto:lightinglayouts@eaton.com)

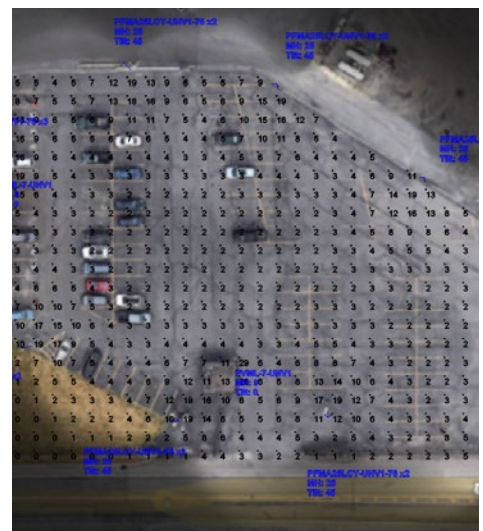
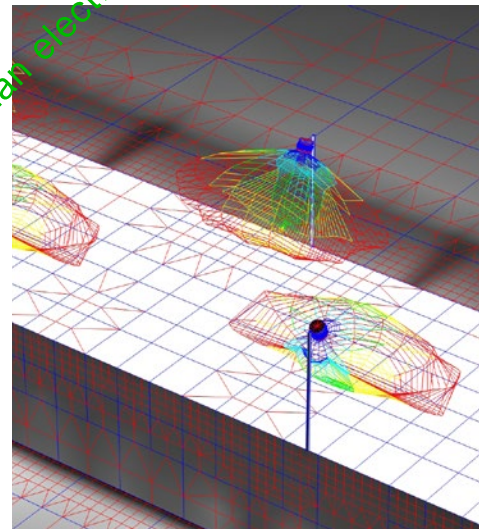

## Complementary products

# V-Spring Telescoping Safety Light Poles

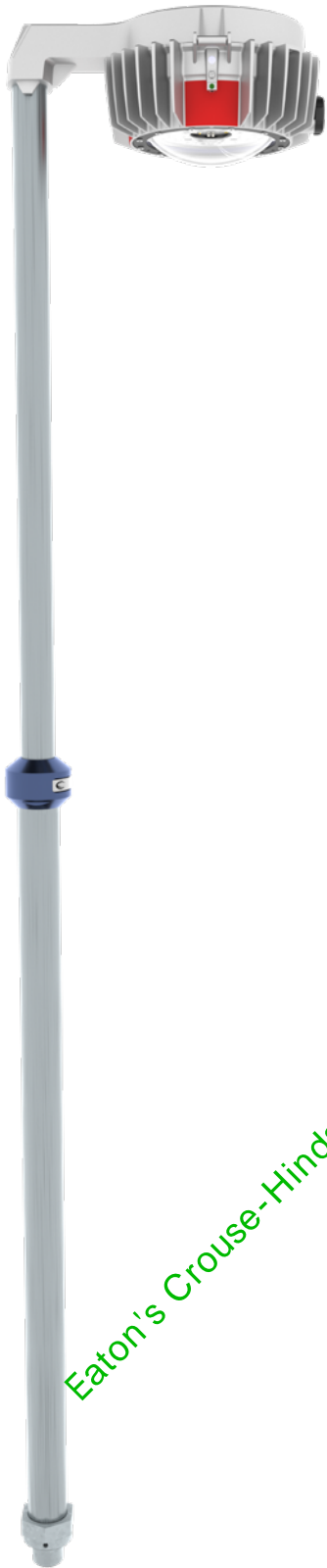

## Enhance safety and simplify maintenance with the V-Spring Telescoping Safety Light Pole—fully compatible with Champ M2/M3 LED luminaires.

The Crouse-Hinds series V-Spring™ telescoping safety light pole is designed for hazardous and industrial environments, making it the ideal mounting solution for Champ M2/M3 fixtures. Its innovative telescoping design allows all installation and maintenance work to be performed safely from the platform or walkway—eliminating the need for portable ladders and fall protection equipment.

### Key Benefits

**Maximum Safety:** All fixture work is performed at ground level, reducing fall risks and improving compliance with OSHA/HSE regulations.

**Labor Savings:** Spring-assisted vertical movement enables quick, controlled raising and lowering of luminaires, minimizing installation and maintenance time.

**Rugged Reliability:** Built for industrial and harsh and hazardous locations, V-Spring poles are rated for corrosive, wet, dusty, hot, and cold conditions.

**Flexible Mounting:** Adjustable 360° pole rotation and telescoping height allow for effortless fixture positioning and coverage in challenging environments.

**Multiple Fixture Capability:** Supports a range of mounting styles and luminaire weights, including the Champ M2/M3 series.

### Applications

- Industrial walkways, platforms, stairways, and conveyors
- Hard-to-reach or dangerous areas
- Locations subject to corrosive agents, vibration, and extreme temperatures



Scan to learn more about V-Spring telescoping safety light pole or visit [Eaton.com/Lighting](https://www.eaton.com/Lighting)



# Complementary products

## Condulet Lighting Tee

### Safe, simple and reliable light pole installation

The Crouse-Hinds series Condulet™ Lighting Tee streamlines light pole installation for hazardous and industrial environments. Its top-entry design and robust construction make it the ideal solution for pairing with V-Spring telescoping safety light poles and Champ™ M2/M3 LED luminaires.

### Key Benefits

**Top-Entry Access:** Easy access for wiring and connections, improving safety and reducing installation time.

**Optimized for V-Spring™:** 1-1/2" vertical hub accepts V-Spring telescoping safety light poles and other standard poles.

**Flexible Installation:** Available in Feraloy® iron alloy or copper-free aluminum, with 3/4" or 1" through-hole hubs to suit various conduit raceways.

### Applications

- Industrial platforms and walkways
- Hazardous locations
- Retrofit and new construction projects

Scan to learn more about the Condulet Lighting Tee or visit [Eaton.com/Condulet](http://Eaton.com/Condulet)



# Complementary products

## Cable Glands

### Solutions for terminating and securing electrical cables in hazardous, industrial, and commercial environments

Whether you need environmental sealing, strain relief, grounding, or explosion protection, Eaton provides cable glands designed for specific cable types and installation requirements. When used with the V-Spring telescoping safety light pole and Champ M2/M3 luminaires, cable glands help ensure safe, compliant, and reliable connections—protecting wiring at the entry point and supporting long-term system integrity.

### Featured solutions

**CGB Series:** For non-armored cables; provides strain relief and is available in multiple materials for wet and hazardous locations.

**TMC3 Series:** For armored and non-armored cables; dual certified for hazardous areas, with robust ingress protection and corrosion resistance.

**ADE Series:** Barrier glands for armored and non-armored cables; offers flameproof and increased safety protection for the most demanding environments.

### Applications

- Hazardous and industrial locations
- Termination of armored and non-armored cables
- Enclosures and junction boxes

Scan to learn more about Cable Glands or visit [Eaton.com/CableGlands](http://Eaton.com/CableGlands)

