

Champ Pro PFMA LED floodlights

9,000 to 15,000 lumens

UL/CSA Certified
Type 4X; IP66/IP67

5L

Our Champ® Pro PFMA LED floodlight is a field-proven design that helps ensure safety, reliability and performance in harsh and heavy industrial areas. Champ products are engineered to deliver more operational value and better total cost of ownership.

Applications:

- For general area illumination of locations with mounting heights from 15 to 30 feet
- Locations requiring continuous and consistent light levels in extreme ambient temperatures
- Where extremely corrosive, wet, dusty, hot and/or cold conditions exist
- IP66/IP67, Type 4X, marine, wet locations and hose down environments
- Manufacturing plants; heavy industrial, chemical, food and beverage facilities; mining; platforms; loading docks; tunnels; outdoor wall and pole mounted areas

Standard materials:

- Lamp housing – die cast aluminum with Corro-free™ epoxy powder coat
- Lens – heat- and impact-resistant glass (standard); diffused glass or polycarbonate (optional)
- Gaskets – silicone
- External hardware – 316 stainless steel
- Factory sealed, no external seals required

LED system:

- High intensity discrete power emitters
- Cool white (5000K, 70 CRI) (standard); deep warm (2200K, 70 CRI), warm white (3000K, 80 CRI) or neutral white (4000K, 80 CRI) (optional)
- NEMA 7x6 or 4x4 optical patterns available
- Dimmable driver, 0-10V
- Rated life of 60,000 hours continuous operation at 55°C operating ambient temperature
- 5 year fixture warranty



Photometrics:

- Refer to www.eaton.com (under the Resources tab of each product family) for specific photometric IES files

Certifications and compliances:

NEC/CEC:

- Marine and wet locations, Type 4X, IP66/IP67
- Operating ambient temperature: -40°C to 65°C

UL standards:

- UL1598 – Luminaires; UL1598A – Marine; UL50; UL50E

CSA standards:

- C22.2 No. 250.0
- C22.2 No. 250.13
- CSA C22.2 No. 94.1
- CSA C22.2 No. 94.2

FCC:

- FCC Part 15 / ICES-005 Ver. 5
CAN ICES-005 (A) / NMB-005 (A)



- CE 2903

Electrical ratings:

Model	Weight Lbs. (Kg.)	Nominal lumens	Efficacy ^A	Wattage	Voltage	Amps	Power factor	THD	Surge protection
PFMA-9-UNV1	24.92 (11.30)	9,261	162 lm/W	58.12	100-277 VAC, 50/60 Hz	0.59 - 0.22	≥ 0.90	≤ 20%	6kV
PFMA-11-UNV1	24.92 (11.30)	11,602	158 lm/W	77.35	100-277 VAC, 50/60 Hz	0.79 - 0.28	≥ 0.90	≤ 20%	6kV
PFMA-13-UNV1	24.92 (11.30)	13,581	154 lm/W	89.60	100-277 VAC, 50/60 Hz	0.91 - 0.32	≥ 0.90	≤ 20%	6kV
PFMA-15-UNV1	24.92 (11.30)	15,845	154 lm/W	106.78	100-277 VAC, 50/60 Hz	1.07 - 0.38	≥ 0.90	≤ 20%	6kV
PFMA-9-UNV3	24.95 (11.32)	9,261	162 lm/W	58.34	347-480 VAC, 50/60 Hz	0.17 - 0.12	≥ 0.90	≤ 20%	6kV
PFMA-11-UNV3	24.95 (11.32)	11,602	158 lm/W	75.01	347-480 VAC, 50/60 Hz	0.22 - 0.16	≥ 0.90	≤ 20%	6kV
PFMA-13-UNV3	24.95 (11.32)	13,581	154 lm/W	90.38	347-480 VAC, 50/60 Hz	0.26 - 0.19	≥ 0.90	≤ 20%	6kV
PFMA-15-UNV3	24.95 (11.32)	15,845	154 lm/W	105.38	347-480 VAC, 50/60 Hz	0.30 - 0.22	≥ 0.90	≤ 20%	6kV

^AConsult IES files for exact performance data.

Champ Pro PFMA LED floodlights

9,000 to 15,000 lumens

UL/CSA Certified
Type 4X; IP66/IP67

5L

INSTALLATION EASE

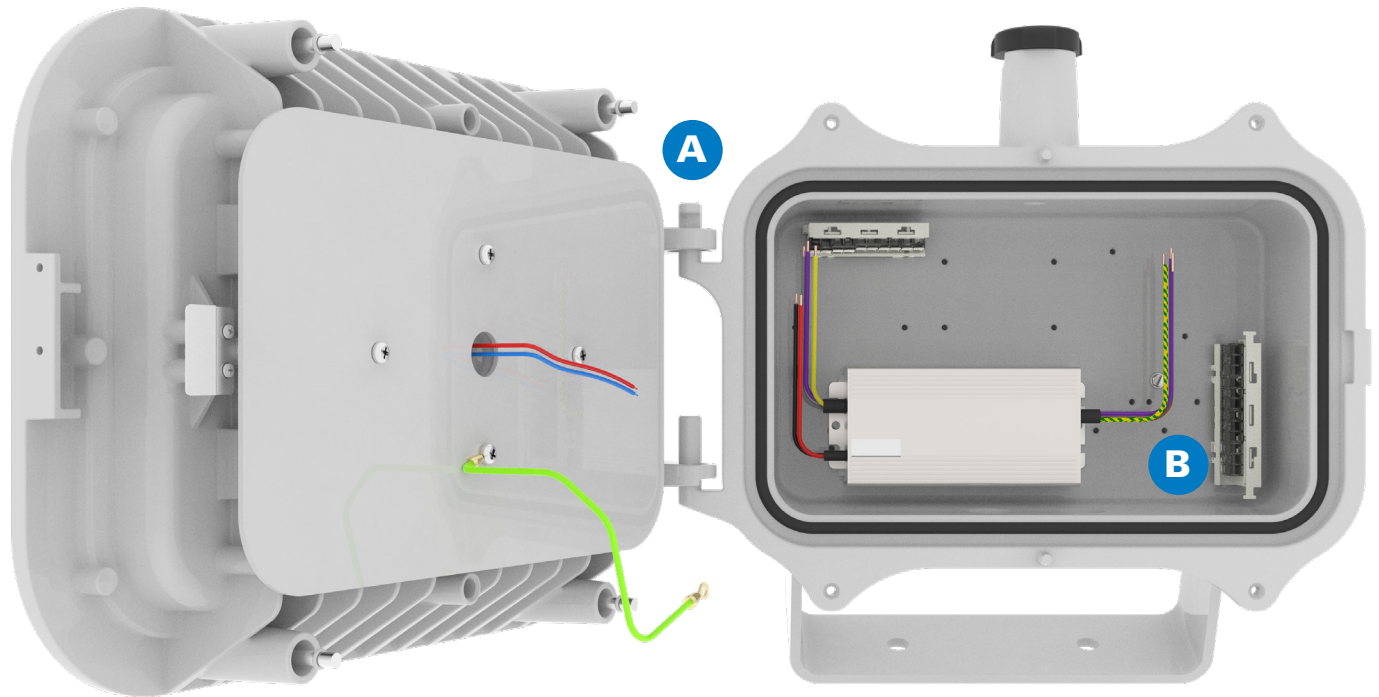

A Lightweight & serviceable

- Driver and light engine subassembly are field replaceable for extended life even beyond the warranty
- Removable cover for LED engine and hinged driver compartment enables faster installation, access to wiring and field maintenance
- 22% weight reduction from previous generation Champ floodlight models

B Now supports up to 10 AWG wire for easier, less costly retrofits!

- Customers with 10 AWG wire already running through their facility from older, higher power HID fixtures can reuse the same wiring
- Plug and play wiring helps speed installation

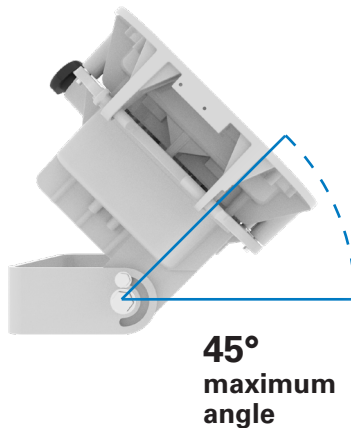
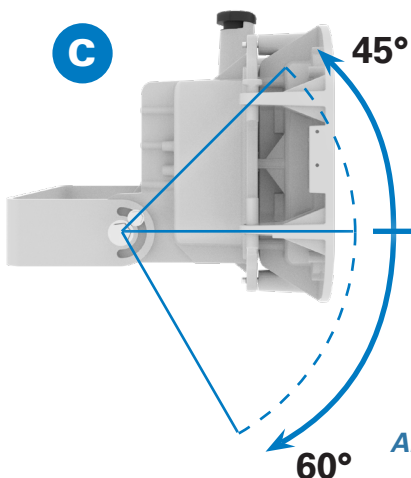
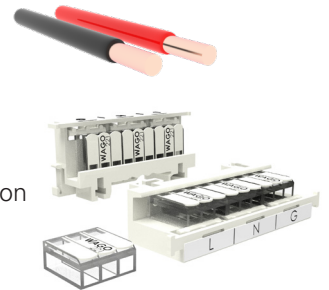

C Versatile mounting options

- Yoke mount and accessories help ensure the fixtures are installed in the correct location to properly light your facility

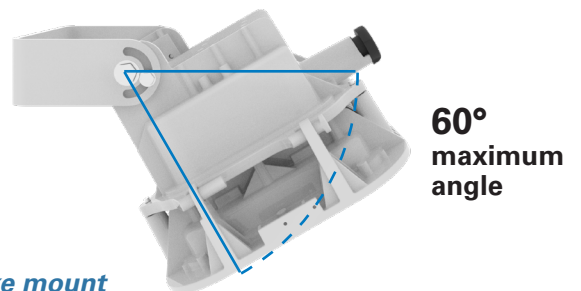

All units come standard with a yoke mount

Champ Pro PFMA LED floodlights

9,000 to 15,000 lumens

UL/CSA Certified
Type 4X; IP66/IP67

5L

RELIABLE PERFORMANCE

D Thermal management

- Heat fins help ensure proper air flow and facilitate dust shedding for effective heat dissipation and thermal management of LED engine and driver

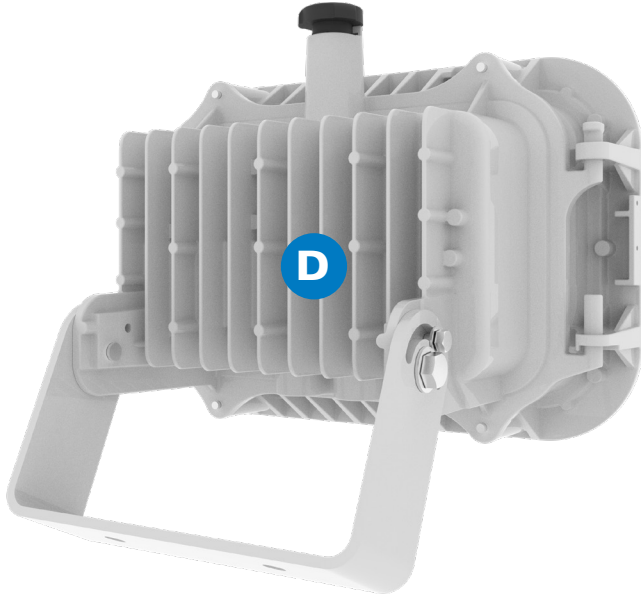

E Performance in extreme environments

- Operating ambient: -40°C to 65°C
- Type 4X, IP66/IP67
- 6kV surge protection
- Corrosion-resistant aluminum housing with Corro-free epoxy powder coating
- Vibration tested to withstand up to 3-axis 3G vibration
- Impact tested in accordance with Section 17.41 of UL1598



OPTIMIZED LIGHT & QUALITY

F Custom optics & colors

- Directs light where you need it, helping eliminate gaps and dark spots
- Can potentially reduce the number of light fixtures required in your application
- 2200K (deep warm), 3000K (warm), 4000K (neutral) and 5000K (cool) color options available



NEMA 4x4

Narrow uniform pattern for use at larger distances



NEMA 7x6

Wide flood distribution provides a large and uniform light pattern



5000K (cool)

Crisp, bright white with a blue hue

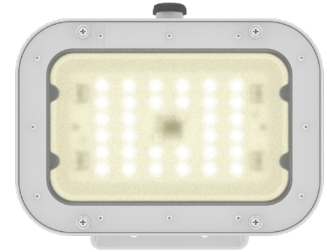

3000K (warm)

Soft, warm white with a yellow hue

G Multiple lens & epoxy powder coat options

- Clear glass lens (standard)
- Diffused glass and clear polycarbonate lenses optional
- Corro-free epoxy powder coat available in gray



H Visor option available for dark sky readiness



Champ Pro PFMA LED floodlights

9,000 to 15,000 lumens

UL/CSA Certified
Type 4X; IP66/IP67

5L

Ordering information:

Part number example

PFMA-9-W-76-M20-DG-V-UNV1-M2

PFMA - 9 - W - 76 - M20 - DG - V - UNV1 - M2

Light source / intensity	
9	9,261 nominal lumens
11	11,602 nominal lumens
13	13,581 nominal lumens
15	15,845 nominal lumens

Color temperature	
BLANK	5000K, 70 CRI (cool white)
N ^B	4000K, 80 CRI (neutral white)
W	3000K, 80 CRI (warm white)
22 ^B	2200K, 70 CRI (deep warm)

Beam pattern	
76	NEMA 7x6
44 ^C	NEMA 4x4

Entries	
BLANK	3/4" NPT
M20	20mm
M25	25mm

Lens material	
BLANK	Clear glass
DG	Diffused glass
PC ^B	Clear polycarbonate

Voltage	
UNV1	100-277 VAC, 50/60 Hz
UNV3	347-480 VAC, 50/60 Hz

Accessories	
BLANK	No accessories
G	Bolt-on wire guard (P63)
V	Standard visor (DSV5)
GV	Bolt-on wire guard (P63) & standard visor (DSV5)

Epoxy powder coat	
BLANK	Gray

Replacement light engine ordering information: PFMA-W-76-DG-V-BZ-ML-LED-KIT^C

PFMA - W - 76 - DG - V - BZ - ML-LED-KIT

Color temperature	
BLANK	5000K, 70 CRI (cool white)
N ^B	4000K, 80 CRI (neutral white)
W	3000K, 80 CRI (warm white)
22 ^B	2200K, 70 CRI (deep warm)

Beam pattern	
76	NEMA 7x6
44 ^C	NEMA 4x4

Lens material	
BLANK	Clear glass
DG	Diffused glass
PC ^B	Clear polycarbonate

Accessories	
BLANK	No accessories
G	Bolt-on wire guard (P63)
V	Standard visor (DSV5)
GV	Bolt-on wire guard (P63) & standard visor (DSV5)

Accessories (ordered separately):

Description

- Bull horn, 2 tenon, gray **BLHN2**
- Bull horn, 3 tenon, gray **BLHN3**
- Bolt-on wire guard **P63**
- Standard visor **DSV5**
- Safety cable **SC831**
- Floodlight slipfitter **SFA6**
- Slipfitter wall mount adapter **SWB6**

Cat.



Replacement driver kits (ordered separately)

FMVA-9-UNV1-M2-DRIVER KIT	UNV1 M2 replacement driver kit for PFMA-9
FMVA-11-UNV1-M2-DRIVER KIT	UNV1 M2 replacement driver kit for PFMA-11
FMVA-13-UNV1-M2-DRIVER KIT	UNV1 M2 replacement driver kit for PFMA-13
FMVA-15-UNV1-M2-DRIVER KIT	UNV1 M2 replacement driver kit for PFMA-15
FMVA-9-UNV3-M2-DRIVER KIT	UNV3 M2 replacement driver kit for PFMA-9
FMVA-11-UNV3-M2-DRIVER KIT	UNV3 M2 replacement driver kit for PFMA-11
FMVA-13-UNV3-M2-DRIVER KIT	UNV3 M2 replacement driver kit for PFMA-13
FMVA-15-UNV3-M2-DRIVER KIT	UNV3 M2 replacement driver kit for PFMA-15

^BContact customer service for lead time.

^CThe model information shown on the kit nameplate takes precedence over the details on the luminaire nameplate regarding LED subassembly features, such as lens type, secondary optics, CCT, and guard/visor. LED light engine kits shall be used with ETL (Intertek) listed Crouse-Hinds hazardous locations luminaires, catalog numbers beginning with PFMA and must end with the M2 suffix.

Champ Pro PFMA LED floodlights

9,000 to 15,000 lumens

UL/CSA Certified
Type 4X; IP66/IP67

5L

Dimensions – standard yoke mount:

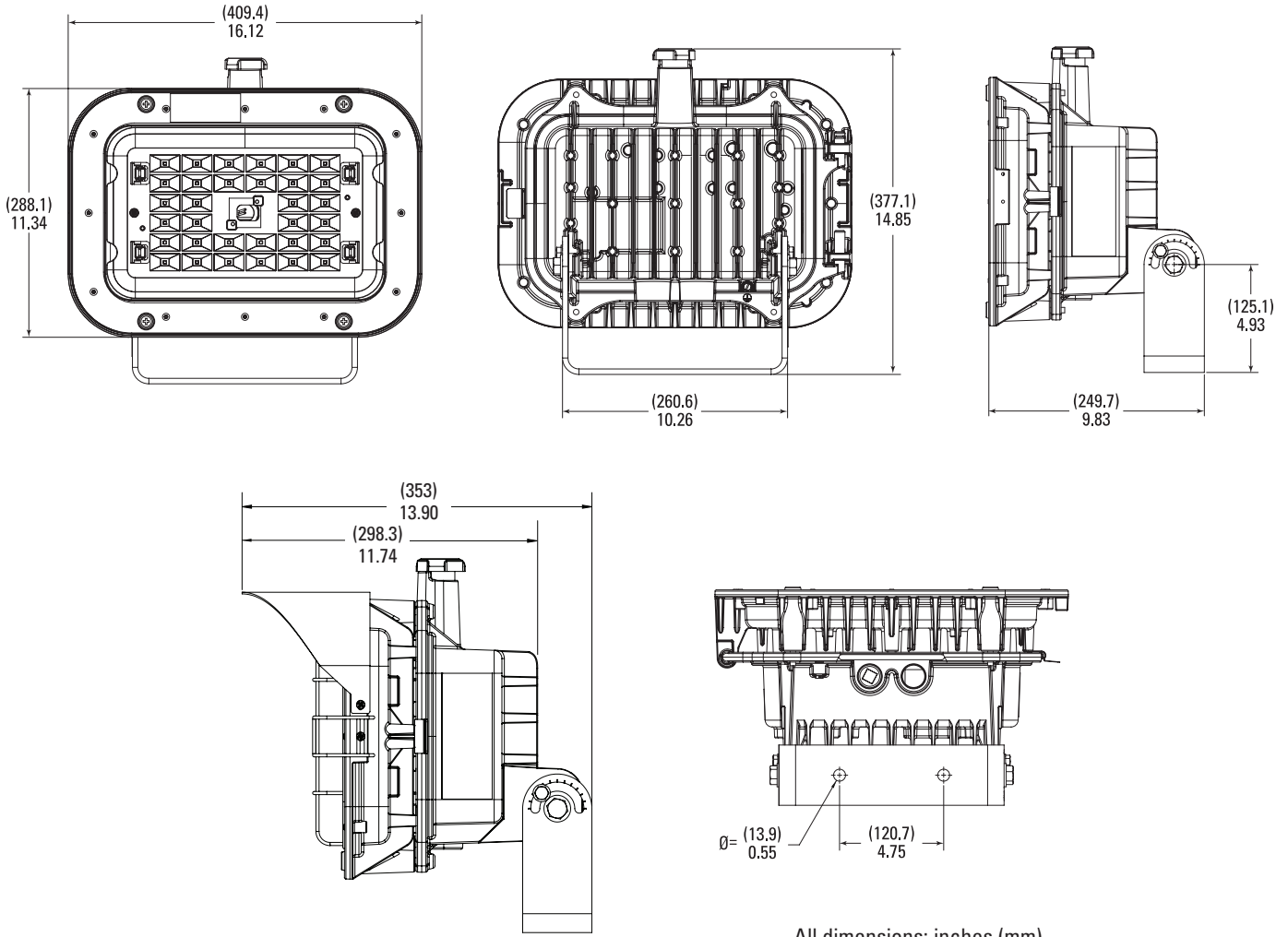

All dimensions: inches (mm)

Mounting method	Angle range	Mounting surface
Yoke (standard)	+45° to -60°	Wall, ceiling, horizontal surface/ground

5L