

Metallic adaptors and reducers - AB and BB

Technical specification

Raxton Exd/Exe adaptors and reducers provide a means of connection between dissimilar thread forms or sizes. Metallic adaptors have a hexagonal body; if space is a critical factor, round adaptors can be offered with an equivalent diameter of the standard hexagonal item.

Raxton adaptors and reducers are marked with the applicable approval number and size.



Type AB Hex



Type BB Hex

Certifications and compliances



Code of protection categories

ATEX: I M2, Ex db I/IIC Mb/Gb, Ex eb IIC Gb, Ex tb IIIC Db

IECEX /

INMETRO /

EAC: Ex d I/IIC, Ex e I/IIC, Ex tb IIIC Db

CSA: CI I Zn 1 AEx db IIC Gb, Ex db IIC Gb (see certificate for threadforms & material details)

CCC: Ex d IIC Gb, Ex e IIC Gb, Ex tD A21 IP6X

Compliance standards

ATEX /EAC: EN 60079-0, EN 60079-1, EN 60079-7, EN 60079-3

INMETRO: ABNT NBR IEC 60079-0, ABNT NBR IEC 60079-1, ABNT NBR IEC 60079-7, ABNT NBR IEC 60079-31

IECEX: IEC 60079-0, IEC 60079-1, IEC 60079-7, IEC 60079-31

CSA: CSA-C22.2 No. 60079-0, CSA-C22.2 No. 60079-1
ANSI/UL 60079-0, ANSI/UL 60079-1

CCC: GB 3836.1-2010, GB 3836.2-2010, GB 3836.3-2010,
GB 12476.1-2013, GB 12476.5-2013

Certificate details

ATEX: ITS16ATEX101336X

IECEX: IECEX ITS160011X

CSA: CSA 200455-1003277 (brass and stainless only)

EAC: TC RUJ-G B.MHO62.B.00447/19

INMETRO: NCC 18.0133X

CCOE: F393297/1

CCC: 2020322313001350 (Adaptors), 2020322313001351 (Reducers)

Temperature

-60°C to +200°C ; depending on O-ring or sealing washer used

Ingress protection (IP):

Independently tested to IP66 / IP68 when fitted in accordance to manufacturer's instructions.

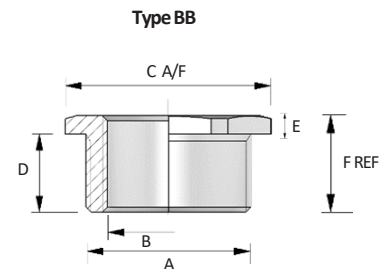
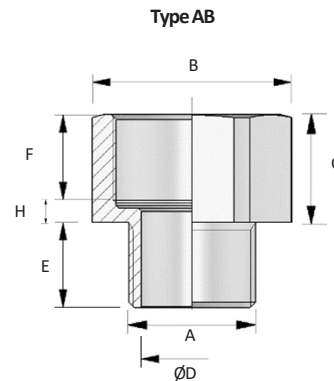

Metallic adaptors and reducers - AB and BB

Dimensions

Type AB

Metallic adaptors are available for up to two step sizing, e.g. M20 male x M32 female

Other sizes / threads are available upon request.

A	B	C	ØD	E	F	G	H
Male metric (6g)	Female metric (6H)	A/F	Bore	Thread length	Thread depth	Ref	Hex wall
M12	M12	15.9	7.0	15.0	17.0	21.0	4.0
	M16	19.1	7.0	15.0	17.0	21.0	4.0
M16	M16	19.1	10.4	15.0	17.0	21.0	4.0
	M20	24.0	10.4	15.0	17.0	21.0	4.0
	M25	30.5	10.4	15.0	17.0	21.0	4.0
M20	M20	24.0	14.4	15.0	17.0	21.0	4.0
	M25	30.5	14.4	15.0	17.0	21.0	4.0
	M32	37.6	14.4	15.0	17.0	22.0	5.0
M25	M25	30.5	19.4	15.0	17.0	21.0	4.0
	M32	37.6	19.4	15.0	17.0	22.0	5.0
M32	M32	37.6	26.8	15.0	17.0	22.0	5.0
	M40	47.2	26.8	15.0	17.0	22.0	5.0
	M50	55.9	26.8	15.0	17.0	22.0	5.0
M40	M40	47.2	33.5	15.0	17.0	22.0	5.0
	M50	55.9	33.5	15.0	17.0	22.0	5.0
M50	M50	55.9	42.8	15.0	17.0	22.0	5.0
	M63	70.1	42.8	15.0	17.0	22.0	5.0
M63	M63	70.1	54.4	15.0	17.0	22.0	5.0
	M75	80.0	54.4	15.0	17.0	22.0	5.0
M75	M75	80.0	66.7	15.0	17.0	22.0	5.0

Type BB

Other sizes / threads are available upon request.

A	B	C	D	E	F
Male metric (6g)	Female metric (6H)	A/F	Thread length	Hex length	Total length
M16	M12 & BELOW	15.9	15.0	4.0	19.0
M20	M16 & BELOW	24.0	15.0	4.0	19.0
M25	M20 & BELOW	27.9	15.0	4.0	19.0
M32	M25 & BELOW	37.5	15.0	4.0	19.0
M40	M32 & BELOW	47.2	15.0	5.0	20.0
M50	M40 & BELOW	55.9	15.0	6.0	21.0
M63	M50 & BELOW	70.1	15.0	7.0	22.0
M75	M63 & BELOW	80.0	15.0	8.0	23.0
M80	M63 & BELOW	90.0	20.0	9.0	29.0
M90	M80 & BELOW	95.0	20.0	10.0	30.0
M100	M90 & BELOW	110.0	20.0	11.0	31.0

Metallic adaptors and reducers - Product coding

DIGIT 1+2		CODE
Product	Description	
ADAPTORS	M-F HEX	AB
REDUCERS	M-F HEX	BB

DIGIT 3	CODE
MATERIAL	
BRASS	A
ALUMINUM	B
STEEL	C
STAINLESS STEEL	E

DIGIT 8 (APPROVAL)	CODE
Exd/Exe	Y
Nylon Exe only	E
None	F

DIGIT 9 (UNDERCUT)	CODE
Yes	U
None	X or Blank

DIGIT 10 (PLATING)	CODE
None	Blank
Nickel	N
Zinc	Z

DIGIT 4+5 (Male thread)						DIGIT 6+7 (Female thread)							
THREAD REFERENCE TABLE													
ISOMETRIC		NPT		BSPT		BSPP		NPSM		PG		ET	
SIZE	CODE	SIZE	CODE	SIZE	CODE	SIZE	CODE	SIZE	CODE	SIZE	CODE	SIZE	CODE
M12	04	½"	42	½"	52	½"	62	½"	72	PG7	20	¾"	31
M16	11	¾"	43	¾"	53	¾"	63	¾"	73	PG9	21	¾"	32
M20	12	1"	44	1"	54	1"	64	1"	74	PG11	22	1"	33
M22	07	1¼"	45	1¼"	55	1¼"	65	1¼"	75	PG13,5	23	1¼"	34
M24	08	1½"	46	1½"	56	1½"	66	1½"	76	PG16	24	1½"	35
M25	13	2"	47	2"	57	2"	67	2"	77	PG21	25	2"	36
M28	09	2½"	48	2½"	58	2½"	68	2½"	78	PG29	26	2½"	37
M32	14	3"	49	3"	59	3"	69	3"	79	PG36	27	3"	38
M38	05	3½"	86	4"	79	4"	89	3½"	90	PG42	28		
M40	15	4"	87	SPECIAL	50	SPECIAL	60	4"	70	PG48	29		
M50	16	SPECIAL	40					SPECIAL	70				
M63	17												
M75	18												
M80	80												
M90	81												
M100	82												
SPECIAL	10												

NOTE: Male thread is always quoted First (Digit 4+5) followed by the Female thread (Digits 6+7)
Other threads are available, please consult the sales department
Digit 8 Approval
Digit 9: U = Undercut Otherwise Blank or use X if Plating is required
Digit 10 (Plating) is Blank if no Plating is required

EXAMPLES							
Product	Material	Male thread	Female thread	Approval	Special	Plating	
Adaptor	Brass	½" NPT	M20	Exd/Exe	None	Nickel	Part Number
AB	A	42	12	Y	Blank	N	ABA4212YN
Reducer	Stainless	M50	1"NPT	Exd/Exe	None	None	Part Number
BB	E	16	44	Y	Blank	Blank	BBE1644Y

Metallic adaptors and reducers – Thread selection / dimensions

Isometric to BS 3643:1981

Size	Major diameter (mm)	Threads per inch	Pitch
16mm (M16)	15.968	16.93	1.50
20mm (M20)	19.968	16.93	1.50
25mm (M25)	24.968	16.93	1.50
32mm (M32)	31.968	16.93	1.50
40mm (M40)	39.968	16.93	1.50
50mm (M50)	49.968	16.93	1.50
63mm (M63)	62.968	16.93	1.50
75mm (M75)	74.968	16.93	1.50

National Pipe Thread to ANSI / ASME: 1983

Size	Major diameter (mm)	Threads per inch	Pitch
1/8" NPT	10.28	27.00	0.94
1/4" NPT	13.72	18.00	1.41
3/8" NPT	17.15	18.00	1.41
1/2" NPT	21.34	14.00	1.81
3/4" NPT	26.67	14.00	1.81
1" NPT	33.40	11.50	2.21
1 1/4" NPT	42.16	11.50	2.21
1 1/2" NPT	48.26	11.50	2.21
2" NPT	60.33	11.50	2.21
2 1/2" NPT	73.03	8.00	3.18
3" NPT	88.90	8.00	3.18
4" NPT	114.30	8.00	3.18

British Standard Pipe to BS 21:1985

Size	Major diameter (mm)	Threads per inch	Pitch
1/8" BSP P	9.736	28.00	0.91
1/4" BSP P	13.16	19.00	1.34
3/8" BSP P	16.66	19.00	1.34
1/2" BSP P	20.96	14.00	1.81
3/4" BSP P	26.44	14.00	1.81
1" BSP P	33.25	11.00	2.31
1 1/4" BSP P	41.91	11.00	2.31
1 1/2" BSP P	47.80	11.00	2.31
2" BSP P	59.81	11.00	2.31
2 1/2" BSP P	75.18	11.00	2.31
3" BSP P	87.88	11.00	2.31
4" BSP P	114.30	11.00	2.31

Other sizes and threads are available including ET, PG, BSPT and NPSM, contact Customer Services for details.

Certified products - Raxton adaptors now available in 2 step format

Adaptors
 Reducers
 Not certified

		Female thread																	
		M16	M20	M25	M32	M40	M50	M63	M75	1/2" NPT/BSP	3/4" NPT/BSP	1" NPT/BSP	1 1/4" NPT/BSP	1 1/2" NPT/BSP	2" NPT/BSP	2 1/2" NPT/BSP	3" NPT/BSP	4" NPT	
Male thread	M16	Adaptor																	
	M20	Reducer	Adaptor																
	M25	Reducer	Reducer	Adaptor															
	M32	Reducer	Reducer	Reducer	Adaptor														
	M40	Reducer	Reducer	Reducer	Reducer	Adaptor													
	M50	Reducer	Reducer	Reducer	Reducer	Reducer	Adaptor												
	M63	Reducer	Reducer	Reducer	Reducer	Reducer	Reducer	Adaptor											
	M75	Reducer	Reducer	Reducer	Reducer	Reducer	Reducer	Reducer	Adaptor										
	1/2" NPT	Reducer	Adaptor																
	3/4" NPT	Reducer	Adaptor																
	1" NPT	Reducer	Adaptor																
	1 1/4" NPT	Reducer	Adaptor																
	1 1/2" NPT	Reducer	Adaptor																
	2" NPT	Reducer	Adaptor																
	2 1/2" NPT	Reducer	Adaptor																
	3" NPT	Reducer	Adaptor																
	4" NPT	Reducer	Adaptor																
	1/2" BSP	Reducer	Adaptor																
	3/4" BSP	Reducer	Adaptor																
	1" BSP	Reducer	Adaptor																
1 1/4" BSP	Reducer	Adaptor																	
1 1/2" BSP	Reducer	Adaptor																	
2" BSP	Reducer	Adaptor																	
2 1/2" BSP	Reducer	Adaptor																	
3" BSP	Reducer	Adaptor																	