

FLS enclosed switches

Cl. I, Div. 1 & 2, Groups C, D
 Cl. II, Div. 1, Groups E, F, G
 Cl. II, Div. 2, Groups F, G
 Cl. III
 NEMA 3, 4, 7CD, 9EFG, 12

Explosionproof
 Dust-ignitionproof
 Raintight
 Wet locations

2A

Heavy duty

Applications:

FLS heavy duty enclosed switches are used:

- In a rigid metallic conduit system for surface mounting adjacent to, or remote from, equipment being controlled
- As disconnect switches for main feed or individual motor control
- To prevent arcing of the enclosed switch from causing ignition of a specific hazardous atmosphere, or atmospheres, external to the enclosure
- In industrial areas, such as chemical plants, oil and gas refineries, paint and varnish manufacturing plants, gasoline bulk loading terminals, grain elevators, grain processing industries, coal processing or handling areas, or metal handling or finishing areas where atmosphere may contain hazardous gases and/or dust
- In non-hazardous areas where sturdy, durable enclosures are required

Features:

- Enclosed devices are unfused, visible blade motor circuit switches
- Rugged cast metal enclosures with mounting lugs and taper tapped hubs with integral bushings, in through feed arrangement
- Interior of the enclosures is readily accessible through threaded cover openings at each end, set at an angle to facilitate wiring
- Threaded covers and a threaded type operating shaft and bushing provide quick assembly and easy maintenance
- A padlock can be used to lock the operating handle in an "ON" or "OFF" position
- Body and cover threads treated with lubricant at factory to provide raintightness

Certifications and compliances:

NEC:

- Class I, Divisions 1 & 2, Groups C, D
- Class II, Division 1, Groups E, F, G
- Class II, Division 2, Groups F, G
- Class III

UL standard:

- UL1203

Environmental ratings:

- NEMA 3, 4, 7CD, 9EFG, 12

Standard materials:

- Body – copper-free aluminum
- Cover – copper-free aluminum
- Shaft – stainless steel
- Shaft bushings – stainless steel

Standard finishes:

- Copper-free aluminum – natural
- Stainless steel – natural

Size ranges:

- Hub size – 1½" through feed with top entry having a PLG5 plug

Options:

- | Description | Suffix |
|--|--------------|
| • Ground/neutral wire stud provided..... | S168 |
| • Breather and drain | S198V |
| • Auxiliary switch: 1A, 1B..... | S784 |
| • Auxiliary switch: 2A, 2B..... | S785 |



Ordering information:

(furnished with non-fusible, visible blade motor circuit switch)

Switch ratings

Amperage	Maximum horsepower rating					Through feed hub size	Cat. # Enclosure with 3-pole switch
	AC 3-phase						
	125V	240V	480V	600V	250 VDC		
30	5	10	20	25	7.5	1½"	FLS30364 1 33
60	10	20	40	60	15	1½"	FLS60364 1 44
100	15	30	75	75	25	1½"	FLS10364 1 55

Dimensions^a (in inches):

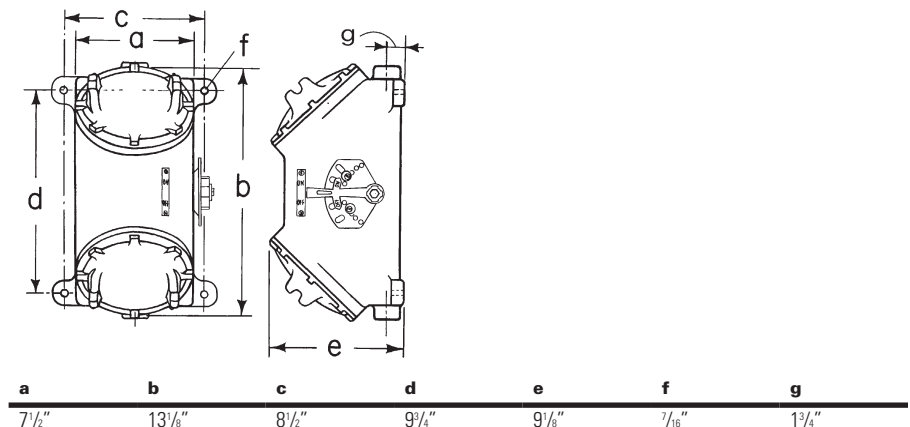

^aDimensions are approximate, not for construction purposes.